

# OPERATING INSTRUCTIONS

## H-827

### PART LIST

NO.	DESCRIPTION	QTY
1	AIR NOZZLE W/BRASS CAP	1
2	FLUID NOZZLE	1
3	AIR DIVERSION RING	1
4	PISTON PAD	1
5	SCREW	1
6	SEAL FOR AIR PISTON	1
7	COMPRESSION SPRING FOR NEEDLE SEAL	1
8	WASHER	1
9	GUN BODY	1
10	FLUID CONTROL KNOB	1
11	SPRING FOR AIR PISTON	1
12	SCREW NUT	1
13	FLUID CONTROL KNOB	1
14	STUFFING BOX FOR AIR PISTON	1
15	GASKET	2
16	AIR PISTON ASSEMBLY	1
17	PISTON RING	1
18	AIR PISTON ASSEMBLY	1
19	SPRING FOR AIR PISTON	1
20	SPINDLE ASSEMBLY	1
21	CONTROL KNOB	1
22	COUNTER SCREW	1
23	AIR ADJUST VALVE ASS'Y	1
24	AIR CONNECTION PIECE R1/4"	1
25	TRIGGER BOLT	1
26	LOCKING PLATE	1
27	BOLT	1
28	TRIGGER SLEEVE	1
29	TRIGGER	1
30	PAINT CONNECTION	1
31	FILTER NET	1
32	PAINT CUP SET	1
33	SPANNER	1
34	CLEANING BRUSH	1
35	HEX SOCKET SCREW KEY	1

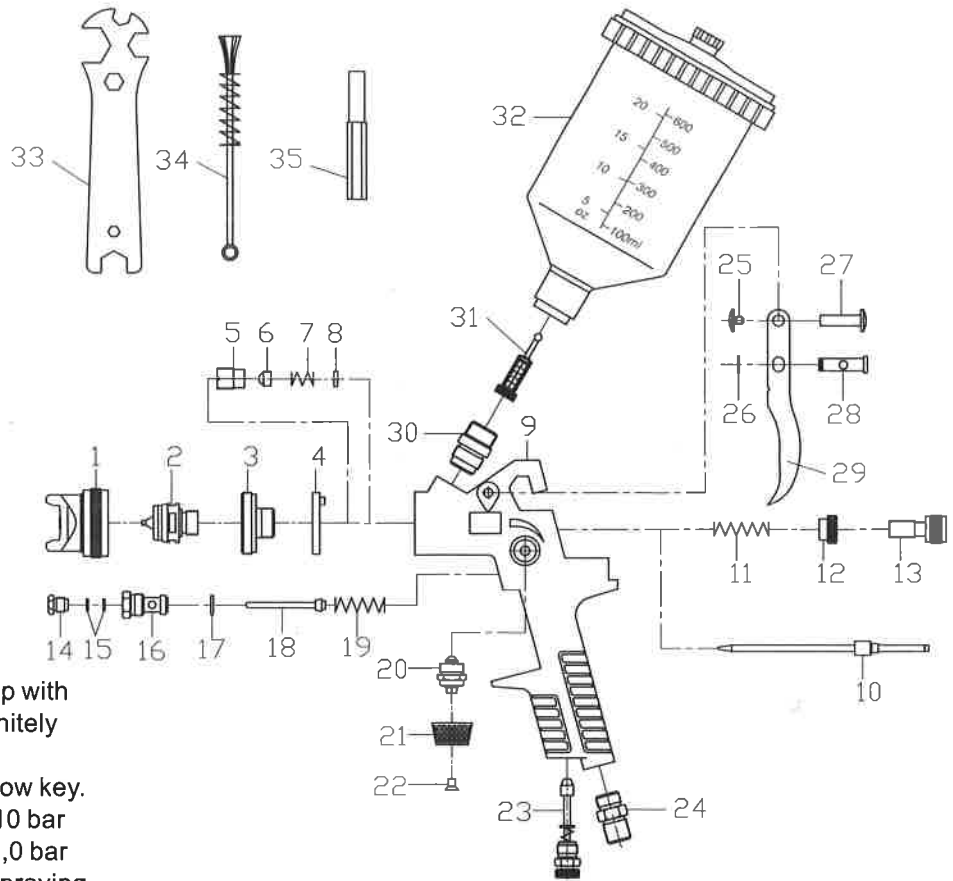

### Features and technical data

Nozzle 1,7 N mm, 0,6 liter plastic cup with integrated drip-catching device, infinitely variable round/flat spray control, Air micrometer, Universal Wrench, Hollow key. Maximum operating pressure over 10 bar (150 psi), operating pressure over 3,0 bar (43 psi), air consumption 12,3 cfm spraying distance 5,9-7,0 in, Weight: 476 g, stainless steel nozzle set.

### 1. Putting into operation

Before putting into operation, and especially after any repair work, check to see that all nuts and bolts are tight. Always disconnect the unit from the air supply before carrying out any repair work.

- Mount the nozzle set tightly. Align the air nozzle so that the number stamped into it can be read from the front the right way round.
- Blow out the air hose before attaching it to the air connection (1/4"). (Air hose pressure-resistant up to min. 10 bar and solvent-resistant. Total electric resistance: less than 100 million Ohm.)
- The paint spray gun has been treated with an anticorrosive agent before leaving the factory and must therefore be flushed out thoroughly with thinner before use.

### 2. Adjusting the volume of air using the compressed-air micrometer

The air supply can be regulated extremely fine to suit all operational conditions. Micrometer in vertical position (parallel to gun body) = maximum atomization. Micrometer in horizontal position (across gun body) = minimum atomization (for blending, etc.). During operation, never remove hollow screw by using the small hollow key in order to remove the micrometer.

### 3. Reduction of the material volume

The volume of material flowing from the nozzle and thus the needle stroke can be reduced steplessly by screwing in the material-volume regulation screw.

### 4. Changing the nozzle set

Always change the complete nozzle set whenever changing nozzle size. These components, which consist of air cap, fluid nozzle and paint needle, are supplied as a complete set. Insert paint nozzle before paint needle.

### 5. Exchanging the air piston and air piston packing

To replace the air piston remove the hollow screw and detach the air micrometer. Pull out spring and air piston. Exchange the air piston. Unscrew stuffing box screw and remove the old packing. Now insert new Packing with flat end first and gently tighten stuffing box screw towards packing.

### 6. Cleaning and maintenance

- Flush the material-conveying parts of the gun thoroughly with thinner.
- Clean the air nozzle with a paint brush or brush. Do not immerse the nozzle in thinner.
- Under no circumstances try to clean clogged orifices using an unsuitable tool, since the slightest amount of damage to the orifices will affect paint atomization or spray patterns.

Possible failures in operation

Trouble	Cause	Repair
1. Gun leaks from fluid tip	1. Foreign substances between fluid tip and needle prevent sealing	1. Clean fluid needle and fluid nozzle in thinner or use new set nozzle
2. Paint merges from fluid needle - needle sealing	2. Self tensioning needle sealing damaged or lost	2. Replace needle sealing
3. Spray pattern in sickle shape	3. Horn air holes or air circuit clogged	3. Soak in thinner, afterwards clean with the nozzle - cleaning needle.
4. Drop like or oval shaped pattern	4. Dirt on fluid pin tip or air outlet	4. Turn air nozzle by 180 degrees. If defective pattern remains, clean fluid tip pin and air circuit.
5. Paint Spray flutters	5. Too little material in cup, fluid nozzle not tight self-adjusting, needle sealing damaged, nozzle set dirty or damaged.	5. Refill material, tighten parts, if necessary clean or replace parts.
6. Material bubbles or boils in paint cup	6. Atomization air flows through the paint channel to the cup. The paint nozzle is not sufficiently tightened. Air nozzle is not completely screwed on, the air nut clogged and the seat is defective or nozzle insert is damaged.	6. Tighten parts accordingly, clean or replace.

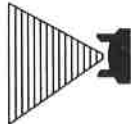

**PLEASE READ BEFORE USE**

**CAUTION!**

When using solvents and cleaning agents based on halogenated hydrocarbons e.g. 1.1.1-trichlorethylene and methylene chloride, chemical reactions can occur on the aluminium cup, gun and on galvanized components (small quantities of water added to 1.1.1-trichlorethylene produce hydrochloric acid). This can cause oxidation of the components: in extreme cases, the reaction can be explosive. Therefore only use solvents and cleaning agents for your paint gun which do not contain the substances named above. Never use acid for cleaning purposes.

**WARNING!**

Never point paint guns at yourself, at other persons or animals. Solvents and diluting agents can cause burns. Before any repair work may be carried out, the unit must be disconnected from the compressed air network and pressure must be released. Before starting to use the paint gun, Particularly after repairs, ensure that screws and nuts are correctly tightened, and check that gun and hoses do not leak. Defect components must be replaced or repaired, use original spare parts only. No sources of ignition (e.g. open flames, burning cigarettes, lamps without ex-protection etc.) may be present during painting, as easily flammable mixtures are generated during the painting process. Occupational safety regulations must be applied when painting (respirator protection etc.). Appropriate ear protection muffs are required, as a sound level of 90dB(A) can be exceeded when painting under higher pressure levels.